

# LUBE-MASTER HIGH VOLUME METER MODULE DIESEL/OIL

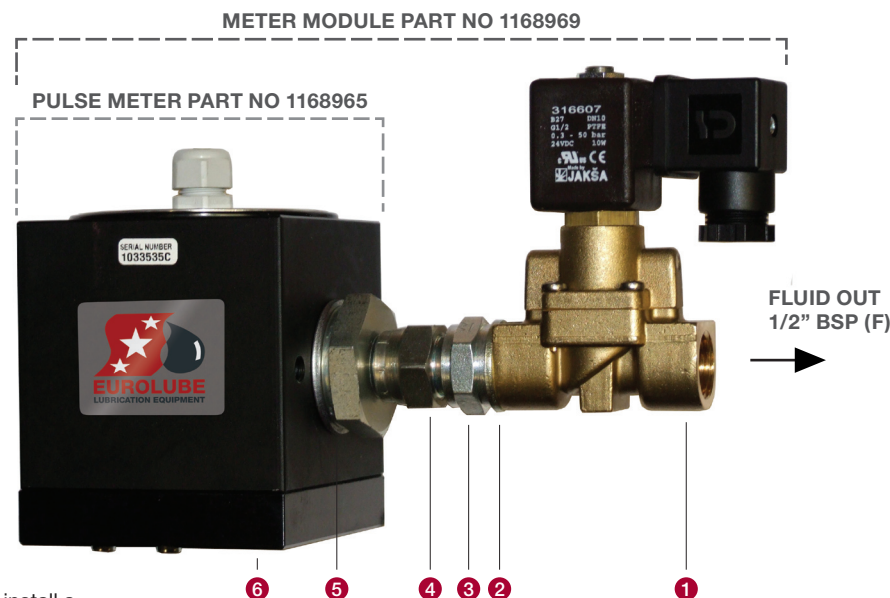

PART NO / ART.NR. 1168969

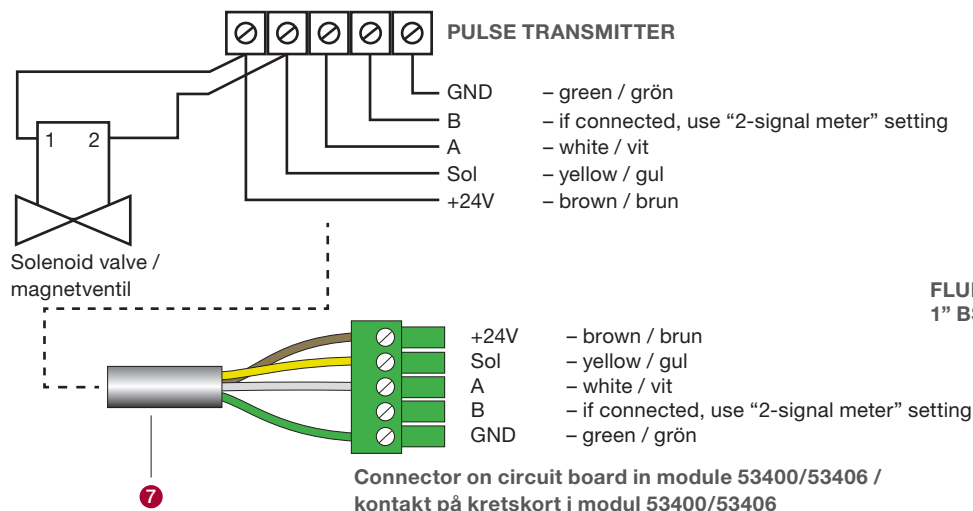

NR	PART NO / ART.NR.	NAME / NAMN
1	1168574	Solenoid valve / magnetventil 24VDC
2	1367347	1/2" Bonded seal / tätningbricka
3	1317181	Adapter 1/2" - 1/2" BSP (M)
4	1357831	Adapter 1" BSP (M) - 1/2" BSP (F)
5	1367266	1" Bonded seal / tätningbricka
6	1168965	Pulse transmitter 36 PPU
7	53393	Signal cable (not included) / signalkabel (ingår ej)

TECHNICAL DATA	
Max pressure / max tryck	5 MPa (50bar)
Min/max temp.	0°C – +50°C
Min/max flow / min/max flöde	1 – 50 l/min
Accuracy / noggrannhet	+/- 0,5%

## GENERAL

The Eurolube electronic meter is designed to dispense motor oils, gear oils, automatic transmission fluid and antifreeze. The transmitter mounted on the meter can be wired to batch controllers, remote counters and other electronically operated instruments that can accept pulses from a reed switch, and have scaling capabilities.

## OPERATION

As fluid passes through the metering chamber by entering the inlet port, the internal gears rotate forcing the fluid to exit through the outlet port. Each rotation of the gear displaces a given volume of fluid. Controlled clearances between the gears and chamber wall insure minimum leakage. As the gears rotate, a magnet on each end of the gear causes the reed switch to open and close. Contact closures from the switch are transmitted to a remote batch controller or counter.

## WARNING!

Whenever there is risk of thermal expansion in the system, ALWAYS install a pressure relief valve to the pump outlet in order to avoid damage to the pulse meter.

## VARNING!

När det finns risk för termisk expansion i systemet, installera ALLTID en tryckbegränsningsventil vid utloppet på pumpen för att undvika skador på pulsmätaren.

## IMPORTANT!

This is a high precision instrument, contamination NOT allowed. Installation: Make sure that the tubes are absolutely clean before installation. After installation bleed the unit slowly.

## VIKTIGT!

Detta är ett precisionsinstrument, föroreningar får EJ förekomma. Installation: Återförsäkra att rörledningen är helt fri från föroreningar före installation. Avlufta enheten långsamt efter installationen.



Pressure relief valve  
PART NO 16765-60



Banjo fitting  
PART NO 16766

EUROLUBE EQUIPMENT AB, Stråsavägen 2, SE-711 76 Storå, Sweden

EMAIL [eurolube@eurolube.com](mailto:eurolube@eurolube.com) PHONE +46 581 836 65 FAX +46 581 409 75

[www.eurolube.com](http://www.eurolube.com)