

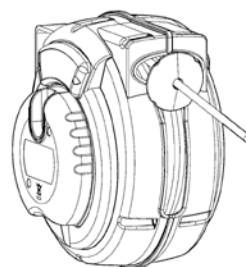

CABLE REEL SERIES E15, A PREMIUM CABLE REEL FOR ALL MARKETS

- A compact premium cable reel
- For professional and frequent use
- Maximum power 2000W
- Pivoting bracket included



VERSATILE MOUNTING & EASY INSTALLATION

Pivoting bracket included

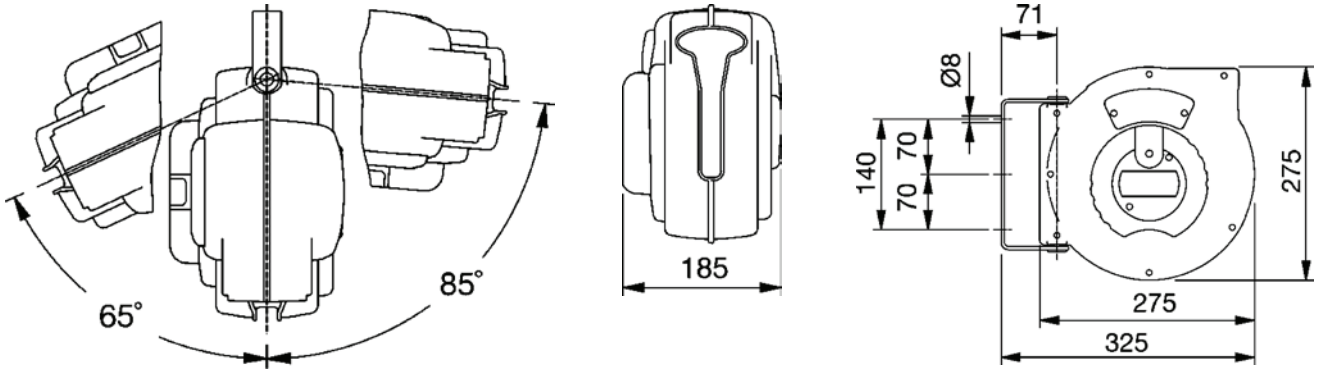

- The cable reel can be fixed to a wall or ceiling using appropriate wall plugs and screws. The bracket requires three Ø8mm screws.
- A locking mechanism allows the cable to be pulled out and latched at the desired length. The mechanism is released by pulling the cable out just beyond the latched position and the cable is then automatically rewound.
- A thermal breaker is built-in for increased safety
- Connect the cable reel to the mains power by means of the supplied plug. *Do not change this plug.*
- The power supply to the cable reel should be single phase 230V 50Hz.
- A RCD (Residual Current Device) protected power supply line is highly recommended.

IMPORTANT: The manufacturer can not be held responsible for injury or damages caused by an incorrect installation.

TECHNICAL DATA - PART NO 55010

Item name	Electric cable reel 15m
Voltage	230V – 50 Hz – 1 Ph
Max. power (W) (completely unwound cable)	2000
Max. power (W) (wound cable)	800
Outlet cable length (m)	15
Inlet cable length (m)	1,3
Cable type	H05VV-F
Cable cross-section (mm ²)	3 x 1,5
Dimensions (mm)	325x275x185
Dimensions (packaging, mm)	290x290x210
Weight (kg)	4,2 (4,6 w/ box)



PART NO 55010



We declare that the product conforms with the EC Directive 89/336/CEE (Electromagnetic compatibility) and the following European standards: EN 61000-1-6, EN 61000-6-3, EN 55014-1-2000 and EN 55014-2-97.



For more information about our complete product range, visit our website, www.eurolube.com



EUROLUBE EQUIPMENT AB

Stråsavägen 2, SE-711 76 Storå, Sweden

EMAIL eurolube@eurolube.com PHONE +46 581 836 65 FAX +46 581 409 75



www.eurolube.com