

NEXU[®]

FLUID MANAGEMENT SYSTEM

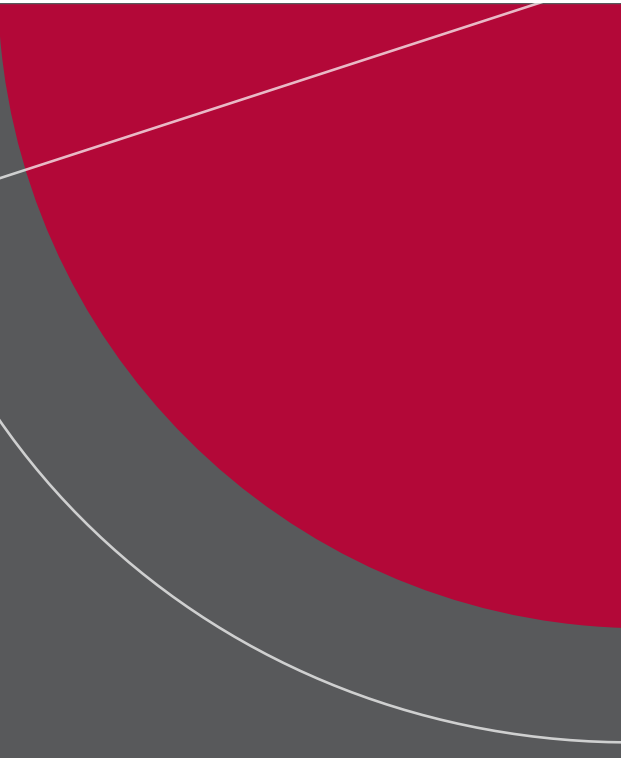

SWEDISH RELIABILITY

ABOUT US

EUROLUBE is a Swedish brand specializing in the distribution and support of environmentally-friendly products and tailor-made complete and professional solutions for the handling of lubricants and fluids. We provide quality products to partners in more than 40 countries.

EUROLUBE's greatest strength is our ability to quickly deliver tailor-made solutions. That, simply, is how we contribute to our partners' efficiency and their profitability.

Our Vision: EUROLUBE is dedicated to quality solutions and support for the lubricant and fluid handling sector.

We do this by developing, manufacturing and supplying products that pump, measure and dose lubricants and fluids, and by delivering these solutions in the most economical and cost-efficient conditions to our partners.

EUROLUBE EQUIPMENT
by Alentec & Orion AB
SWEDEN
www.eurolube.com



OPERATION

EUROLUBE delivers high quality turnkey solutions for professional and environmentally-friendly handling of lubricants and fluids. Our range covers everything from advice to complete customized systems. These may include for example, air operated pumps and accessories of its own design, and advanced electronic devices for metering and measuring. This means precise control of dosage and flow measurement. With our LUBE-Master system makes it easy to connect to existing management systems. Our aim is to constantly develop our concept of always being able to offer cost effective solutions with cutting edge technology. EUROLUBE products are used by companies in the automotive workshops, manufacturing, shipping, mining and agriculture sectors.

COMMITMENT AND FLEXIBILITY THE CUSTOMER IS OUR PARTNER

We are recognized for our instant support and our comprehensive interpretation of our partners' needs, for fast order acknowledgement and for short lead times. Our expert command of the rules that apply to the installation of equipment, is a strength we pass on to our partners. Reliable lead times, flexibility and total commitment are our trademarks.

We always strive for long term business relationships. We therefore feel it is very important for new customers to get to know who we are and how we think just as we always aim to understand our new customers. In plain language, we always invest the time to visit you, to learn about your operation and to establish a person-to person connection. Interested? Please contact us to find out more about our opportunities for a winning concept.



You need to control your

It is more than likely that your stock control for parts and consumables is well established, with charges for those items passed to customers as a matter of course. But can you reconcile your oil purchases with oil sales and usage? Do you know where every litre of oil is used? Do you know how much just "disappears"?

Lost inventory equals lost profit. With today's high oil prices, Inventory Control eliminates that concern.



Why NEX·U®

NEX·U® provides you with the control and the information you require to make your operation more profitable. You will be able to account for every drop of lubricant and other service fluid used.

On top of this, you will carry an efficient inventory control, with automatic alerts and fluid reordering when needed, eliminating operations downtime.

For almost any lubricant usage or operation size, with today's high cost for these fluids, NEX·U® quickly pays for itself. Once it is paid for, savings go right to the operation's bottom line in the form of profit, profit previously lost.



NEX·U® adapts to your way of working.

NEX·U® is a hybrid system that brings you all the advantages of wireless flexibility and hard-wired reliability:

Wireless flexibility

Data can be transmitted wirelessly among the different system components, eliminating long and expensive cable runs.

- Easily adds new components when required as your needs grow.
- System uses existing Wi-Fi® networks, simplifying its installation. No need for special, custom made, network components.

Hard-wired reliability

- A constant and reliable power source is always present to power the solenoid valves that control fluid delivery.
- No uncharged batteries to let you down.
- Hard-wired data transmission to avoid interferences and other obstacles which might interfere with wireless data transmission.

fluids inventory

NEX·U® combines the Latin word "NEXUS", which means connection to wireless or hard-wired connected system components, with "U" (You), the system User, the Human.

NEX·U® has been conceived with the user in mind, making fluid management and fluid inventory control an easy and trouble free activity.

NEX·U® contributes to increase productivity in vehicle service operations:

- Provides total control and record of every fluid dispensed.
- Secures fluid access to authorized technicians only.
- Provides accurate, real time fluid inventory information.

NEXUS + YOU = NEX·U®

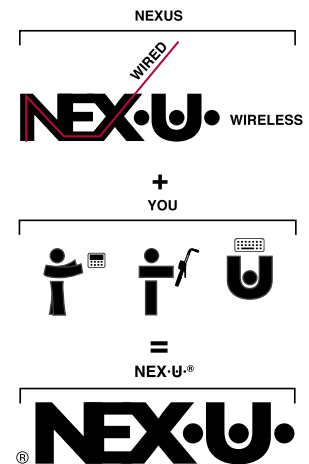

Main components



U·net

NEX·U® Central Processing Unit. Controls and manages all functions and communications, wired or wireless.



U·track

NEX·U® software. Included together with the U-net. It is the interface between the user and the system. Generates useful reports, keeps control of inventory and can communicate with multiple DMS.



U·dat

Systemterminal. Med inbyggd fullfärgsdisplay, pekskärm och QWERTY-tangentbord. Ger komplett åtkomst till NEX·U® och mjukvara.



U·vision+

Hand-held display with access keypad and U-track.



U·valve

All-in-one flow control unit. Includes pulse meter, solenoid valve, filter and electronic board for operation control and communication with other system components.



U·tank

Provides real-time inventory control and manages different alarm signals.

U·net: NEX·U·®

System Central Processing Unit

U·net is the key NEX·U·® component. It is the central processing unit that controls the system communications and houses the U·track software.

U·net includes a powerful 2.4 GHz processor and 4 GB RAM. It controls the system functions and it manages the wired and wireless communication between the NEX·U·® components.

It has two CAN BUS ports (in/out) for wired communications with other NEX·U·® components and an ethernet port that allows U·net to connect to the LAN.

*Eurolube may deploy a dedicated network with an additional Wi-Fi® router (U·net is not a router), contact Eurolube for further information.

U·net



U·net specifications:

- Intel 2,4 GHz processor
- 4 GB RAM memory
- 64 GB storage capacity
- One Ethernet connection, one HDMI, four USB and two CAN BUS communication ports
- 110-240V AC - 5V DC transformer included.

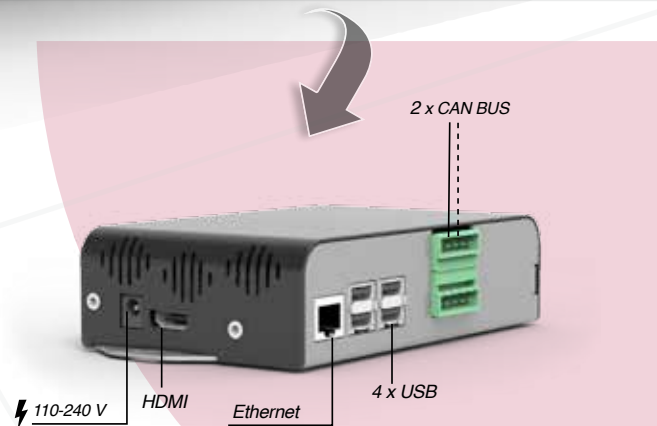
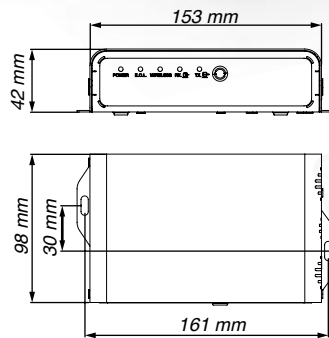

U·net also includes the U·track software.

U·track is a powerful web based software package that gives you full control of fluid usage and inventory. It is a web based software that allows multi-user applications. All PCs or tablets in the same network and in the same location can have access to U·track. U·track can work using any web browser.

Compatible with: Chrome, Firefox, Microsoft Edge.

Thanks to U·track you will be able to:

- Simple and intuitive system set-up.
- Simplified system maintenance (manage users, fluid inventory, etc.).
- Manage all the system hard-wired and wireless communication.
- Generate a wide variety of reports, which can be easily exported to CSV and txt formats.
- Record and manage Validated Preset Transactions (required for operating with U·Vision+)
- Transform any PC terminal in the workshop into a NEX·U·® virtual keypad license required.

U·track also contributes to increase your operations efficiency and profitability:

- Keeps control of every fluid drop dispensed in the system.
- Improves inventory accuracy, generating automatic warnings and email notifications for reorders at critical predefined inventory levels.
- Generates a variety of reports, to help you track dispense information such as date and time, technician, work order, fluid dispensed, volume delivered, etc.

U-track: NEX·U.® Software

Utrack

U-track system is a web based application accessible through any device (laptop, Pc, tablet or cell phone) connected to the same network as U-net.
A virtual keypad license converts any device connected to NEX·U.® into a virtual keypad, making it an accesible for dispensing fluids.

U-track dashboard screen.
In a glance, provides information on oil inventory and oil usage. Just click on any tank for more information.

Transactions can be followed and monitored on a real-time basis if required. Thanks to U-track, each PC terminal or tablet connected to the same network used by NEX·U.® is converted into an access keypad to the NEX·U.® system (additional licenses may be required).
U-track can also generate different reports that can be exported easily into CSV format.

ORDERING INFORMATION

PART No.	DESCRIPTION
53800	U-net central processing unit. Includes U-track software.
53801	Virtual Keypad license. Converts any terminal (PC, laptop, tablet or smartphone) into a NEX·U.® access Keypad.

Dispensing mode options

Standard mode

After entering their PIN and work order number, the technician must select the type of fluid to be delivered, the hose reel number and enter the volume to deliver.

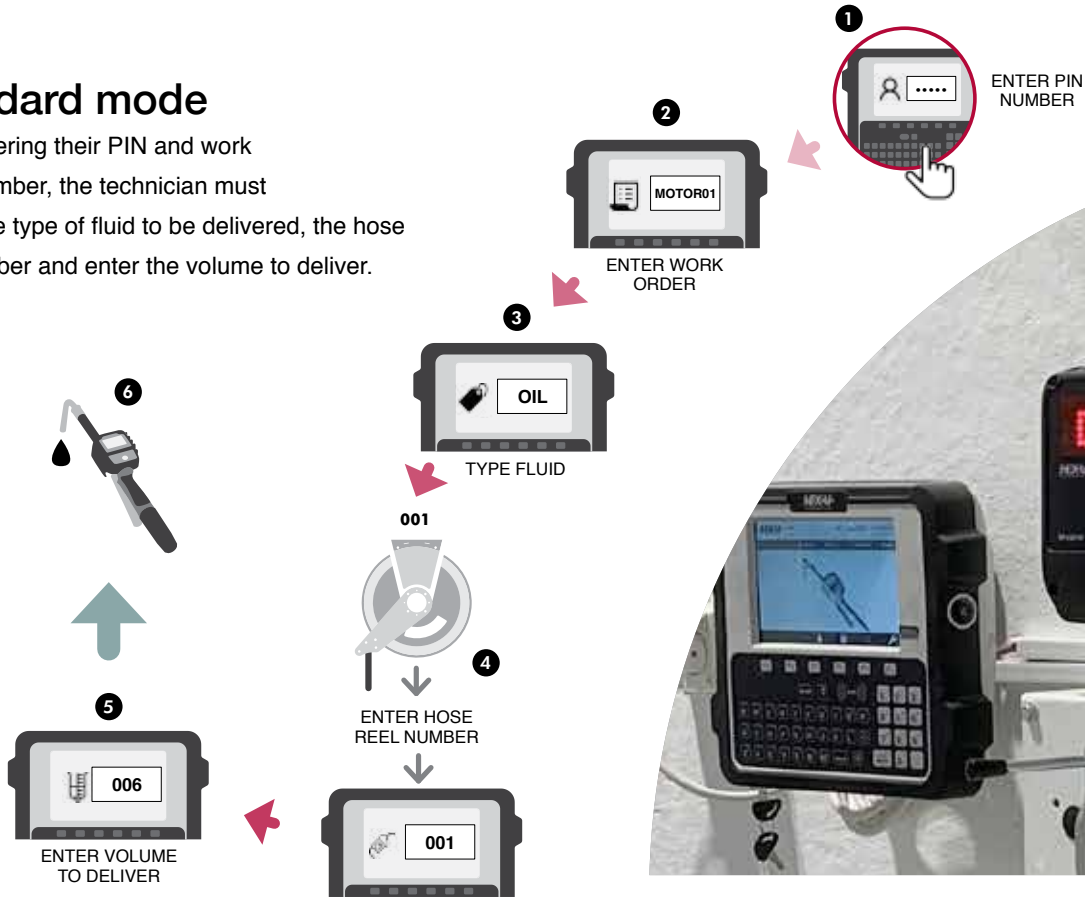

Preset mode

A previous set up must be done before validation, as figure 0 shows.

After the technician enters their PIN, work order and hose reel number, the system downloads the preset volume and the type of fluid associated to the work order entered.

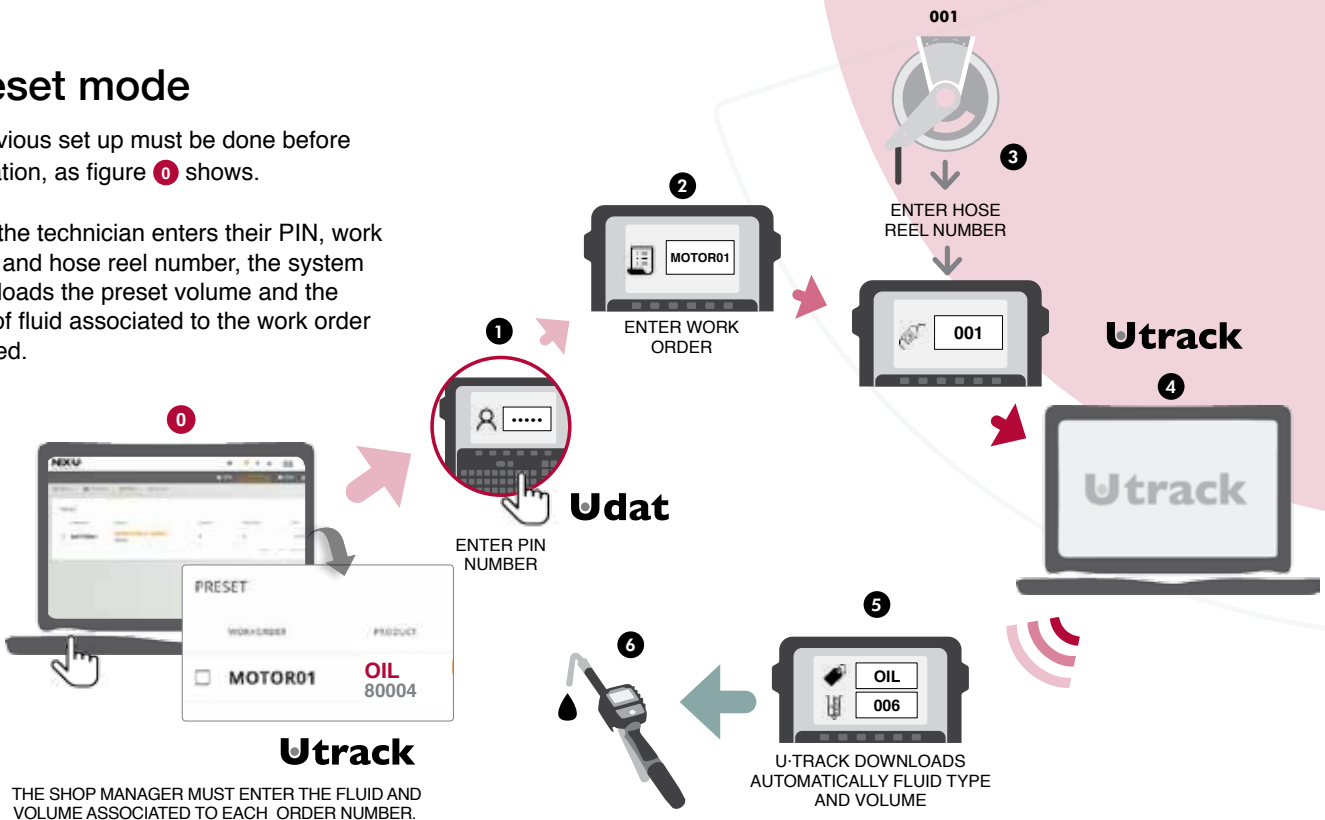

DMS - Dealer Management System Interface

NEX·U[®] can interface with most popular DMS on the market, offering an efficient bidirectional communication to integrate the transaction information workshop DMS.

Features

- Easy to use: quick and effective.
- Enhanced security: work orders are checked and validated before fluid is dispensed.
- Automation: simplifies data entering as it can be automatically downloaded from the DMS
- Contact your EUROLUBE AB Distributor who will assist you with the license software you need.

Udat



ENTER PIN NUMBER

Unet



U-NET SENDS DATA TO DMS



CHECKS AND VALIDATES THE INFORMATION

NEX·U[®] Interface

A bidirectional communication is established through web service. The user enters their PIN number and the work order. DMS will prompt a message whether this information exists or not.

NEX·U[®] offers multiple operating modes depending on the customer needs.

Bi-directional integration with DMS used by most brands

NEX·U[®]

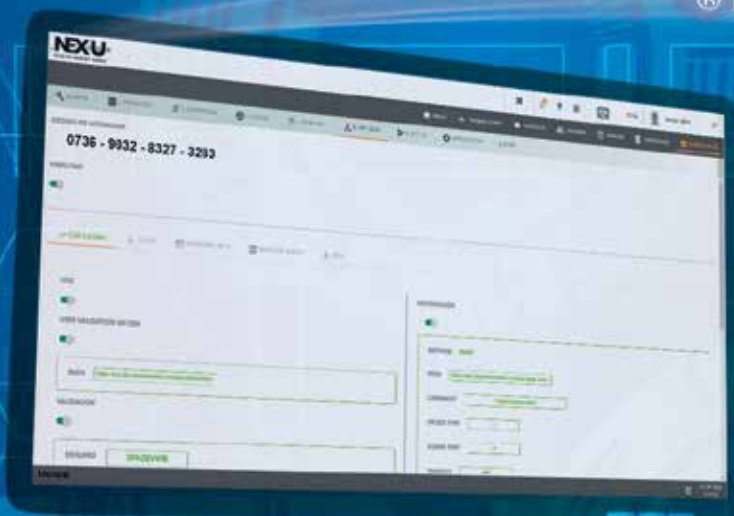

System access: Multiple Possibilities

NEX·U® adapts to the way you work and it offers multiple possibilities for accessing the system.

Technicians can access NEX·U® via:

- U-dat: System access keypad.
- U-vision+.
- Any device connected to the same network as U-net (laptop, smartphone or tablet).



Udat Udat power+

U-dat: Access Keypad

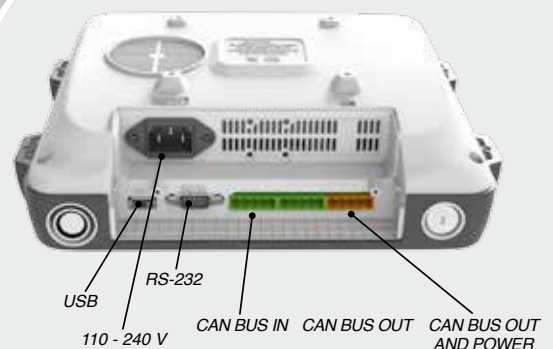

U-dat connection panel.

All wired connections can be quickly and easily done without opening the U-dat. It is possible to connect a printer, an external RFID reader or a barcode reader to the RS-232 port.

U-dat:

- 110 - 240 V AC
- CAN BUS in/out

System Access Keypad. U-dat allows system access to technicians either through a PIN code or using a RFID card.

- U-dat includes a 7" full colour graphics display and a complete QWERTY keypad.
- U-dat supports CAN BUS cable communications that transmits data and power to open the solenoid valves in the system. "Plug-and-play" connectors make cabling easy.
- U-dat includes the transformer required to simultaneously open up to 8 solenoid valves.
- U-dat requires 110 - 240 V power supply.
- Optional Bluetooth printer (see accessories).

ORDERING INFORMATION

PART No.	DESCRIPTION
53821	U-dat power+ keypad NEX·U® access keypad with 7" colour screen and QWERTY keypad. One USB, one RS232 and in/out CAN BUS ports. 110 - 240 V AC, with a 320 W transformer to open 8 solenoid valves, supports CAN BUS communications.
53820	U-dat keypad Same as above, but with a 75 W transformer to open 2 solenoid valves.

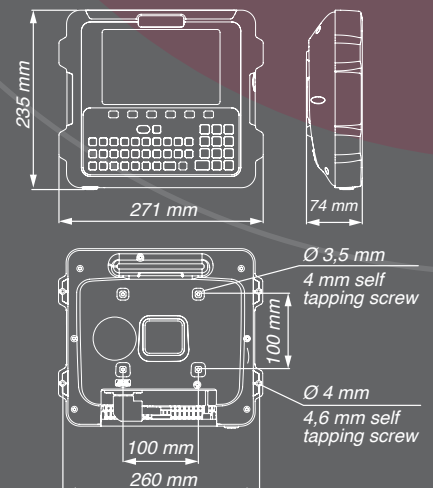

Product specifications are subject to change without prior notice.

U·vision⁺: Hand-held display and keypad module

U·vision⁺ includes a six-button keypad and it can replace the U-dat keypad for data entry in the system as it allows the following operations:

- User access through PIN entry.
- Scroll through existing open job orders to select the one corresponding to each operation or enter the job order number (digits only).
- Enter the volume of fluid to be dispensed.
- Confirm fluid type and transaction.

U·vision⁺ has a backlight display connected using Bluetooth[®] with a U·valve, U·meter⁺ or U·count and it displays the following parameters:

U·vision⁺ is powered with 4 "AA" 1.5 V alkaline batteries.

U·vision⁺

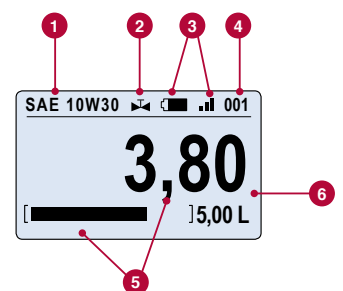

- 1 Fluid dispensed type.
- 2 Solenoid valve open or closed.
- 3 Battery life and Bluetooth[®] signal.
- 4 Hose reel / fluid outlet number.
- 5 Volume delivered and operation progress.
- 6 Preset volume.

Two possible dispensing modes: Standard and Preset



FOUR SCROLL /
NAVIGATION BUTTONS

ENTER BUTTON



ENTER TECHNICIAN
PIN NUMBER

STANDARD MODE



ENTER / SELECT JOB
ORDER NUMBER



ENTER VOLUME
TO DELIVER

PRESET MODE



SELECT
TRANSACTION

U·vision⁺ adapts to any EUROLUBE oil control handle and transforms the handle into a hand-held display and keypad for access to the NEX·U[®] system.

ORDERING INFORMATION

PART No.	DESCRIPTION
53831	U·vision ⁺ hand-held keypad and display module (oil gun not included).

Volume Meters

NEX·U® obtains dispensed volume information from oval gear meters. These meters transmit a pulse per each fraction of volume that goes through them. NEX·U® recognizes and processes these pulses to shut down the corresponding solenoid valve, once the preset volume is reached and to maintain inventory control and pump operation.

Pulse meters are placed in the dispense line, so they are not subject to accidental damage and cannot be by-passed or tampered with. They effectively count every fluid drop.

There are different meter models to meet the needs of each application.



Component	Pulse Meter	Solenoid Valve	Communication Module	Bluetooth®	Wi-Fi®	Materials and Inlet / outlet ports available
U-valve	Yes	Yes	Yes	Yes	-	Aluminium 1/2"
U-valve+	Yes	Yes	Yes	Yes	Yes	
U-meter	Yes	-	Yes	-	-	Aluminium 1/2" and 3/4"
U-meter+	Yes	-	Yes	Yes	-	
U-pulsar	Yes	-	-	-	-	PVC & SS 1/2"
U-count	-	-	Yes	Yes	-	N/A

Uvalve

Uvalve+ Complete meter unit

U-valve is a compact unit combining a high accuracy pulse meter, a solenoid valve and a large cleanable fluid screen filter with an electronic module. This module is required to control the meter and valve operation and to communicate with other system components.

- Reduces installation time and eliminates the risk of leaks when using separate components.
- It has a large, high visibility LED display which shows the U-valve number assigned in the system and the U-valve operation.
- Four coloured LED lights that show the U-valve operation for diagnosis and two buttons for system configuration.
- U-valve supports CAN BUS cable communication that transmits data and the electric power required to open the solenoid valve and Bluetooth® connection to a U-vision or a U-vision+ fluid handle with display.
- U-valve+ includes Wi-Fi® communications for data transmission to other system components. (Requires U-power or U-power+ power supply units).
- U-valve and U-valve+ require 24 V DC supplied by a U-dat or a U-power module.



PRODUCT SPECIFICATIONS

Wetted parts	Aluminium, NBR, stainless steel, acetal
Applications	Lubricants, antifreeze solutions * if fluid additives are used, it is recommended to install stainless steel pulse meter and stainless steel solenoid valve
Connection threads	1/2" BSP (F)
Flow range	1 - 30 l/min
Pulses per litre	328 ppl
Accuracy	+/- 0,5 %
Maximum working pressure	100 bar
Solenoid valve	24 V DC
Communication	CAN BUS, Bluetooth®, Wi-Fi® (U-valve+ only)



U-valve and U-valve+ wired connections use fast connection in/out CAN BUS terminals.

U-valve cable connectors are not included (see accessories).

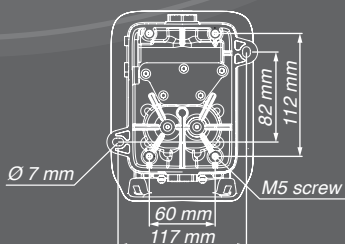
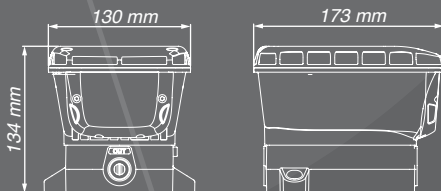

ORDERING INFORMATION

PART No.	DESCRIPTION
53850	U-valve meter, solenoid valve and electronic module. Includes Bluetooth® communication for connecting to a U-vision or U-vision+.
53851	U-valve+ meter, solenoid valve and electronic module. Includes Bluetooth® connection to a U-vision or U-vision+ and Wi-Fi® for data transmission to other components in the system.

U-meter U-meter+

High accuracy, compact pulse meter including the electronic module required to control the meter and valve operation and to communicate with other system components through CAN BUS.

- The meter has an LED display showing the U-meter number assigned in the system, four coloured LED lights that show the U-meter operation for diagnosis and two buttons for system configuration.
- Equipped with fast connection in/out CAN BUS terminals.
- Available in different materials and sizes to match different applications.

U-meter+ includes Bluetooth® connection to a U-vision or a U-vision+ module.



53864

53861

U-meter+ includes Bluetooth® for connecting to a U-vision or U-vision+.

U-meter PART No.	53860	53866	53862	53864
Wetted parts	Aluminium, NBR, stainless steel, acetal	Aluminium, NBR, stainless steel, acetal	PVC, Vectra®, stainless steel, Viton®	Stainless steel, Vectra®, Viton®
Applications	Lubricants	Lubricants, diesel	DEF/AdBlue®, windshield wash and antifreeze solutions	DEF/AdBlue®, windshield wash and antifreeze solutions
Connection threads	1/2" BSP (F)	3/4" BSP (F)	1/2" BSP (F)	1/2" BSP (F)
Flow range	1 - 30 l/min	8 - 80 l/min	1 - 50 l/min	1 - 50 l/min
Pulses per litre	328 ppl	109 ppl	320 ppl	320 ppl
Accuracy	+/- 0,5 %	+/- 0,5 %	+/- 0,5%	+/- 0,5%
Maximum working pressure	100 bar	100 bar	30 bar	100 bar
Communications	CAN BUS	CAN BUS	CAN BUS	CAN BUS
U-meter+, models with Bluetooth® PART No.	53861	53867	53863	53865

Only for connection with U-dat, U-valve, or an adjacent U-meter. Requires a 24 V DC solenoid valve.

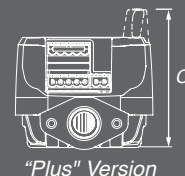
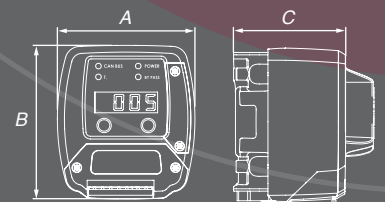

	53860	53861	53866	53867	53862	53863	53864	53865
A (mm)	86	86	86	86	86	86	86	86
B (mm)	96	96	96	96	96	96	96	96
C (mm)	70	86	101	117	73	86	70	86

Ucount



U-count Fluid control module includes a high visibility LED display and the software required to function with the rest of the NEX·U® system components. The LED display shows the number assigned in the system and four colour LED lights show the operation of the valve for diagnosis and two buttons for system configuration. U-count supports CAN BUS hard-wired communication that transmits data and power required to open the solenoid valve, for data communication with other system components and Bluetooth® to communicate with a U·Vision or U·Vision+ handle.

U-count dimensions:

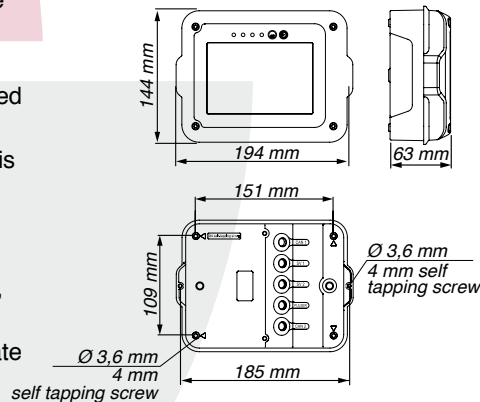

U-pulser



U-pulser high accuracy in-line pulse meter. Equipped with connection terminal and valve open indication light. Only for connection to a U-count module. This meter does not have a display or function buttons and requires a 24 V DC solenoid valve.

ORDERING INFORMATION

U-count PART No.	53836				
DESCRIPTION	Fluid meter and solenoid valve controller includes Bluetooth®, CAN BUS communications.				
U-pulser meter PART No.	1168813	1168816	1168815	1168814	53868
Wetted parts	Aluminium, NBR, stainless steel, acetal	Aluminium, NBR, stainless steel, acetal	PVC, Vectra®, stainless steel, Viton®	Stainless steel, Vectra®, Viton®	Aluminium, acetal, NBR, Stainless steel
Applications	Lubricants, antifreeze solutions	Oil, glycol, coolant solutions, diesel	DEF / AdBlue®, windshield wash and antifreeze solutions	DEF / AdBlue®, windshield wash and antifreeze solutions	Oil, glycol, antifreeze solutions, diesel
Connection threads	1/2" BSP (FF)	3/4" BSP (FF)	1/2" BSP (FF)	1/2" BSP (FF)	1" BSP (FF)
Flow range	1 - 30 l/min	8 - 80 l/min	1 - 50 l/min	1 - 50 l/min	10 - 80 l/min
Pulses per litre	328	110	320	320	110
Accuracy	+/- 0,5 %	+/- 0,5 %	+/- 0,5 %	+/- 0,5 %	+/- 0,1 %
Maximum working pressure	100 bar	100 bar	30 bar	100 bar	100 bar

NEX·U[®] Compact

NEX·U[®] also offers solutions to smaller workshops where web based software is not needed. NEX·U[®] COMPACT is a simple system based in a special U-dat keypad that is able to control a maximum of 8 dispensing points.

The Keypad includes a 7" colour screen and a simplified version of the U-track software. The software included provides workshops with:

- Full control of bulk stored fluid usage.
- Inventory control using declining balance method. NEX·U[®] Compact will give a warning signal once a certain inventory is reached, and restricts access to those outlets that have run out of inventory.
- Ability to generate full reports in CSV format that can provide useful management information.

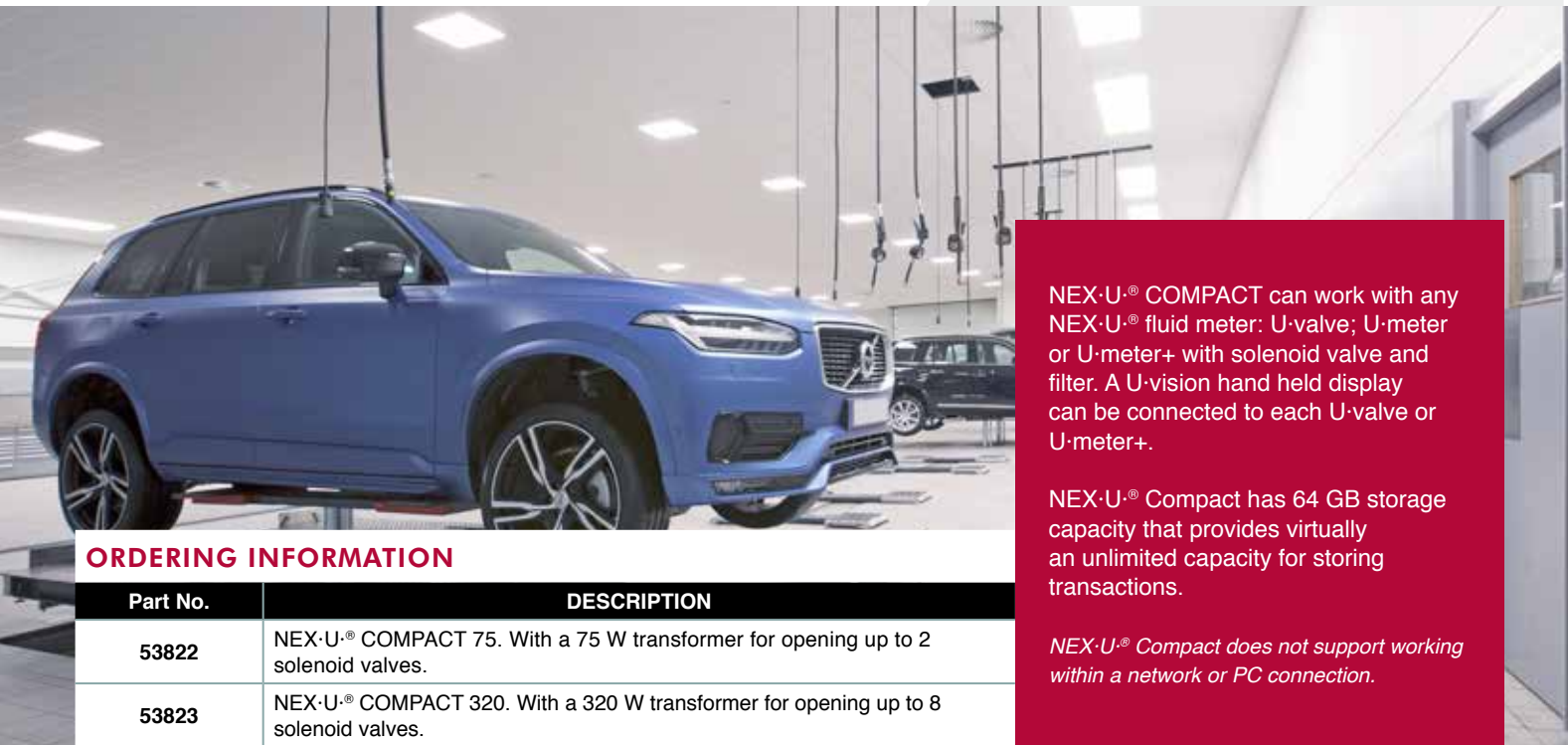

ORDERING INFORMATION

Part No.	DESCRIPTION
53822	NEX·U [®] COMPACT 75. With a 75 W transformer for opening up to 2 solenoid valves.
53823	NEX·U [®] COMPACT 320. With a 320 W transformer for opening up to 8 solenoid valves.

NEX·U[®] COMPACT can work with any NEX·U[®] fluid meter: U-valve; U-meter or U-meter+ with solenoid valve and filter. A U-vision hand held display can be connected to each U-valve or U-meter+.

NEX·U[®] Compact has 64 GB storage capacity that provides virtually an unlimited capacity for storing transactions.

NEX·U[®] Compact does not support working within a network or PC connection.

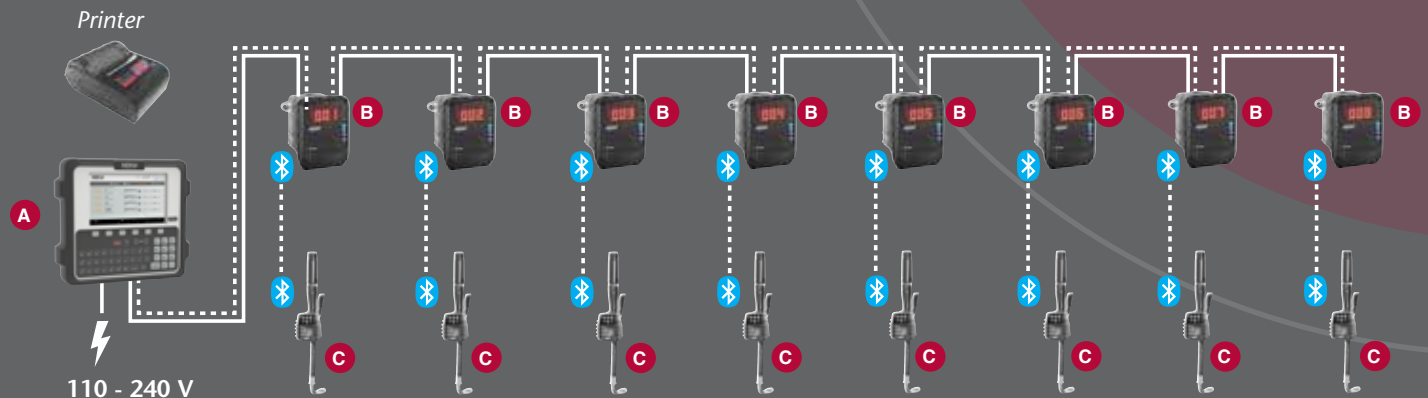

NEX·U[®] COMPACT keypad **A** can control 8 dispensing points (model with 320 W transformer) or 2 dispense point (model with 75 W transformer). Each dispensing point **B** can include a U-valve, a U-meter or U-meter+ with solenoid valve combination. A U-vision hand held display **C** can be connected to each fluid outlet using Bluetooth[®] communications. It is possible to include a Bluetooth printer to provide a ticket for the transactions.

Configuration has to be done through a PC.

NEX·U·[®] Mobile

Fluids in service trucks require similar controls to those in any service centre.

NEX·U·[®] MOBILE allows fluid inventory and usage control in mobile service trucks.

A special U-dat keypad module, which includes the software required for an autonomous operation, can control up to a maximum of 8 fluid outlets. Completed transactions can be saved to a USB memory stick in an Excel format.



NEX·U·[®] MOBILE can work with any NEX·U·[®] fluid meter: U-valve; U-meter or U-meter+ with 24V DC solenoid valve and filter.

Standard U-count and U-pulser solenoid valve are compatible with NEX·U·[®] MOBILE as long as they are connected to a 24 V DC solenoid valve.

ORDERING INFORMATION

PART No.	DESCRIPTION
53824	NEX·U· [®] MOBILE keypad.

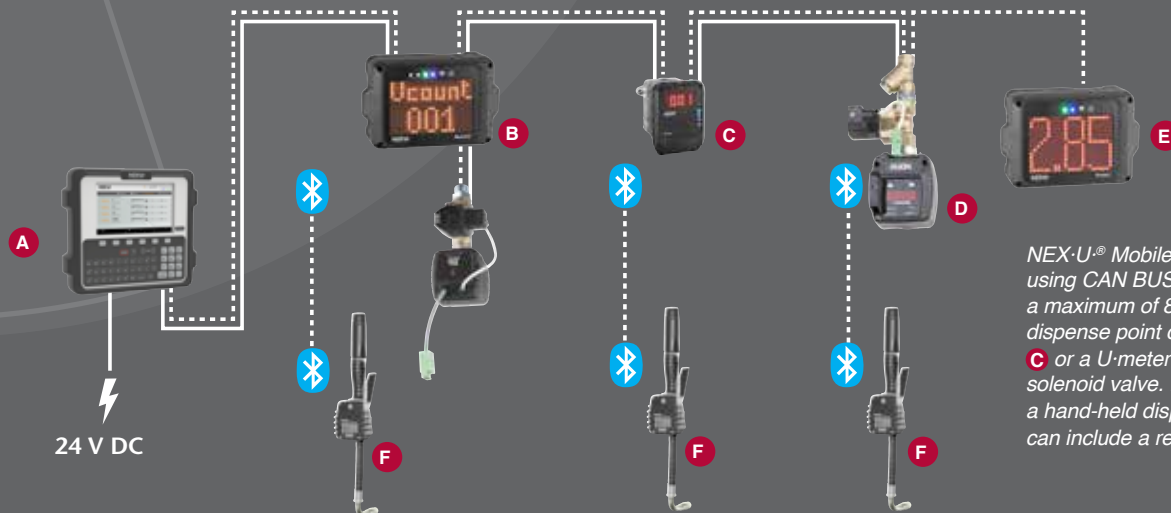

NEX·U·[®] Mobile keypad **A**, connects using CAN BUS cable (power and data) to a maximum of 8 dispensing points. Each dispense point can have a U-count **B**, U-valve **C** or a U-meter+ or U-meter **D** with a 24 V DC solenoid valve. Each dispense point can have a hand-held display U-vision **F** and the system can include a remote display U-view **E**.

NEX·U[®] Remote Displays

Uvision

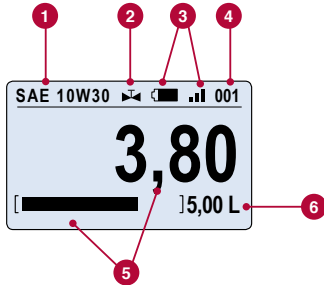

- 1 Fluid dispensed type.
- 2 Solenoid valve open or closed.
- 3 Battery life and Bluetooth[®] signal.
- 4 Hose reel / fluid outlet number.
- 5 Volume delivered and operation progress.
- 6 Preset Volume.

Hand-held display module to fit a EUROLUBE oil control handle. Includes a backlight display connected via Bluetooth[®] with a U-valve, U-meter+ or U-count module and it displays the following parameters:

- Hose reel (fluid outlet number and fluid dispensed type).
- Battery life and Bluetooth[®] signal strength.
- Volume delivered and operation progress.
- Solenoid valve open or closed.

ORDERING INFORMATION

PART No.	DESCRIPTION
53830	U-vision hand-held display module (oil gun not included).



Uview



Remote, high visibility, LED display that shows the volume delivered through various U-valves (no simultaneous operation supported). U-view supports Wi-Fi[®] and hard-wired communication.

U-view requires hard-wired connection (data and power) to a U-dat keypad or to a 110 - 240 V AC power supply using a 24 V DC external transformer (U-power or U-power*).

ORDERING INFORMATION

PART No.	DESCRIPTION
53835	U-view remote display module.

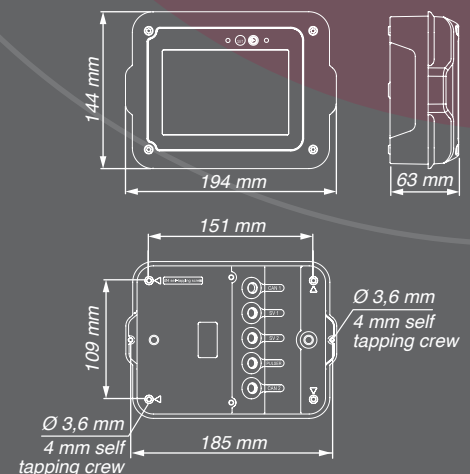

Tank Level Monitor Module

Provides real-time inventory control, reducing concerns about running out of inventory or used fluid tanks overflow.

U-tank



The number of input and output ports are:

- One analogical input per tank for a pressure probe with 4-20 mA or 0-10V.
- Three digital inputs per tank for a low, intermediate or high-level probe (1).
- One output per tank for a solenoid valve to control air supply to each pump.
- One output per tank for an electro-pneumatic valve to prevent tank overflow.
- One output for controlling an air solenoid valve to stop the air supply to all pumps when the workshop is closed.
- One output per tank for controlling a flash warning light or an acoustic alarm.

U-tank supports CAN BUS wired communication with other NEX-U® system components. It requires a 110 - 240 V AC supply.

⁽¹⁾The use of digital probes does not allow real-time inventory monitoring. NEX-U® will use declining balance for inventory control and will require manual inventory adjustment when fluid is supplied to the tank.

It is a monitor module capable of controlling two tanks using digital or analogical level gauges. Can be connected to solenoid valves to control pump operation, and to external warning devices.

U-tank has two independent graphic displays and level bars. Each of them shows the inventory available in each tank. It also has a set-up keypad for inventory adjustment if required.⁽¹⁾

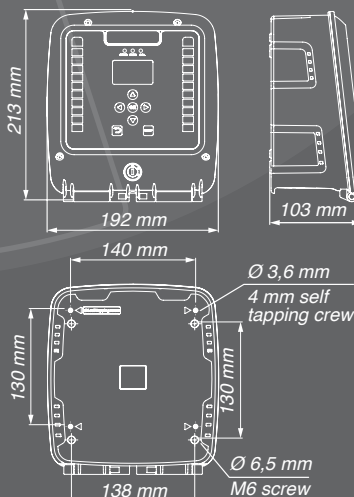

ORDERING INFORMATION

PART No.	DESCRIPTION
53829	U-tank tank monitoring module. Can control up to two tanks. Supports CAN BUS communications. 110 - 240 V

U-meter and solenoid valve kits

U-meter

U-meter and solenoid valve kits include a high precision U-meter or U-meter+ meter, a solenoid valve and a Y-strainer.

PART No.	Application	Pulse meter	Solenoid valve	Y-strainer
53870	Lubricants, glycol	U-meter 53860	1168574	18822
53871	Lubricant, glycol	U-meter+ 53861		
53872	Lubricant, glycol with high fluids	U-meter 53866	1168964	18859
53873	Lubricant, glycol with high fluids	U-meter+ 53867		
53874	Diesel fuel	U-meter 53866	1168980	
53875	AdBlue®, windshield wash (low pressure)	U-meter 53862	1168578	18822
53876	AdBlue®, windshield wash (low pressure)	U-meter+ 53863		
53877	Windshield wash	U-meter 53864	1168574	
53878	Windshield wash	U-meter+ 53865		



SOLENOID VALVES

NEX·U.® requires 24 V DC, normally closed solenoid valves to operate. U-valve and U-valve+ include a solenoid valve. For other metering elements, a solenoid valve compatible with the fluid and the application requirements must be used.



1168574



1168964

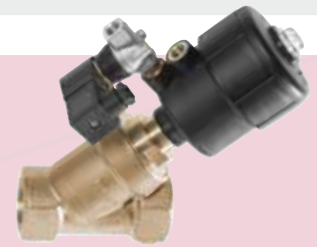

1169895

PART No.	Application and wetted materials	Connection threads	Voltage	Type	Max. Working pressure
SOLENOID VALVES FOR FLUIDS					
1168574 (1)	Oil and antifreeze solutions. Brass and NBR	1/2" BSP (F)	24 V DC	N.C.	50 bar
1168964	Coolant, diesel, water,oil. Brass and NBR	3/4" BSP (F)	24 V DC	N.C.	50 bar
1168578	DEF / AdBlue®; antifreeze and windshield wash solutions, stainless steel and EPDM	1/2" BSP (F)	24 V DC	N.C.	10 bar
1168985	Electro-pneumatic valve. Prevents over fill of waste fluid tanks. Brass and NBR	1-1/2" BSP (FF) for fluids 1/4" BSP (FF) for air	224 V DC and 1 - 4 bar compressed air	N.O.	10 bar
SOLENOID VALVES FOR COMPRESSED AIR – PUMP CONTROL					
3318791	Compressed air. Brass and NBR	1/2" (F)	24V DC	N.C.	10 bar
3368514	Compressed air. Brass and NBR	1/4" (F)	24 V DC	N.C.	10 bar
3318795	Compressed air. Brass and NBR. ATEX approved.	1/4" (F)	24 V AC/DC	N.C.	10 bar

N.C.= Normally closed.

N.O.= Normally open.

(1) for use in standard delivery applications, with a 1/2" U-meter.

Upower+

Upower



53826, 53827



53828

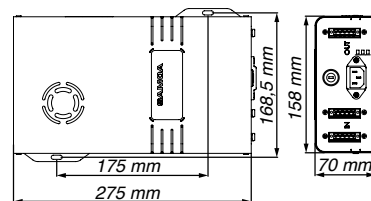

Power supply to solenoid valves and other system components. U·power connects using CAN BUS cable to a U·valve, U·valve+, U·meter, U·meter+, U·count or U·view whenever the power supplied by a U·dat keypad is not present.

PART No.	DESCRIPTION
53827	U·power+. Power supply unit with a 320 W transformer for use with 8 solenoid valves with 2 CAN BUS connectors.
53826	U·power. Power supply unit with a 75 W transformer for use with 2 solenoid valves.
53828	U·power+. Power supply unit with a 320 W transformer for use with 8 solenoid valves with 3 CAN BUS connectors (1 IN and 2 OUT).

Uconnect



53881

CAN BUS TO WIFI CONVERTER

PART No.	DESCRIPTION
53881	U·connect allows wireless communication among the different components of the system. Equipped with an external antenna, it allows for extended signal coverage. It can be configured from a Windows or Android application.



On request

BLUETOOTH PRINTER

PART No.	DESCRIPTION
On request	Optional printer for use with NEX·U·® COMPACT, connected via Bluetooth to the U·dat.



53407

BAR CODE READER

PART No.	DESCRIPTION
53407	Bar code laser reader. Reads any one dimensional code. For use with a U·dat, U·dat Power+ and U·dat for NEX·U·® MOBILE and COMPACT systems.



53882

U·valve BRACKETS

PART No.	DESCRIPTION
53882	Allow fixing U·valve on top of a hose reel stand (360 160).



On request

KEYPAD BRACKETS

PART No.	DESCRIPTION
On request	Universal VESA bracket.

NEX·U.®

Accessories

CABLE

3082A 15/18AWG communication and power CAN BUS cable.

PART No.	DESCRIPTION
53890	CAN BUS communication cable.

PART No.	DESCRIPTION
53892	Jumper cable. 0,5 m cable with prewired connectors 381 908 for connecting adjacent elements with a CAN BUS cable.

PART No.	DESCRIPTION
53891	In/out electrical connectors. For use with U-meter, U-meter+.

U-valve CONNECTORS:

PART No.	DESCRIPTION
53886	Allows wiring connection between U-valves.



53890



53892



53891



53886

TANK MONITORING ACCESSORIES

PART No.	DESCRIPTION
53417	Tank level pressure gauge. Allows real-time monitoring of the volume in a tank. Maximum tank depth 350 cm.

PART No.	DESCRIPTION
53287	Digital level gauge. Detects minimum, intermediate or maximum volume in a tank. Does not allow real-time monitoring. Adjustable height, includes 5 m cable.

PART No.	DESCRIPTION
53883	Remote flash and acoustic alarm.

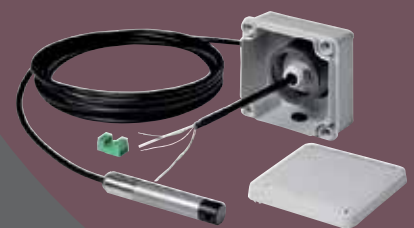

53417



53287



53883

Creating a Wireless Network

There are two ways to create a wireless network:

- Using an existing Wi-Fi® network. Requires access to existing wireless network credentials.
 - Creating a dedicated Wi-Fi® network. New wireless credentials are created for this network.
- In both cases IP addresses, network and default gateway, are required. The key component is U-net.

USING AN EXISTING NETWORK

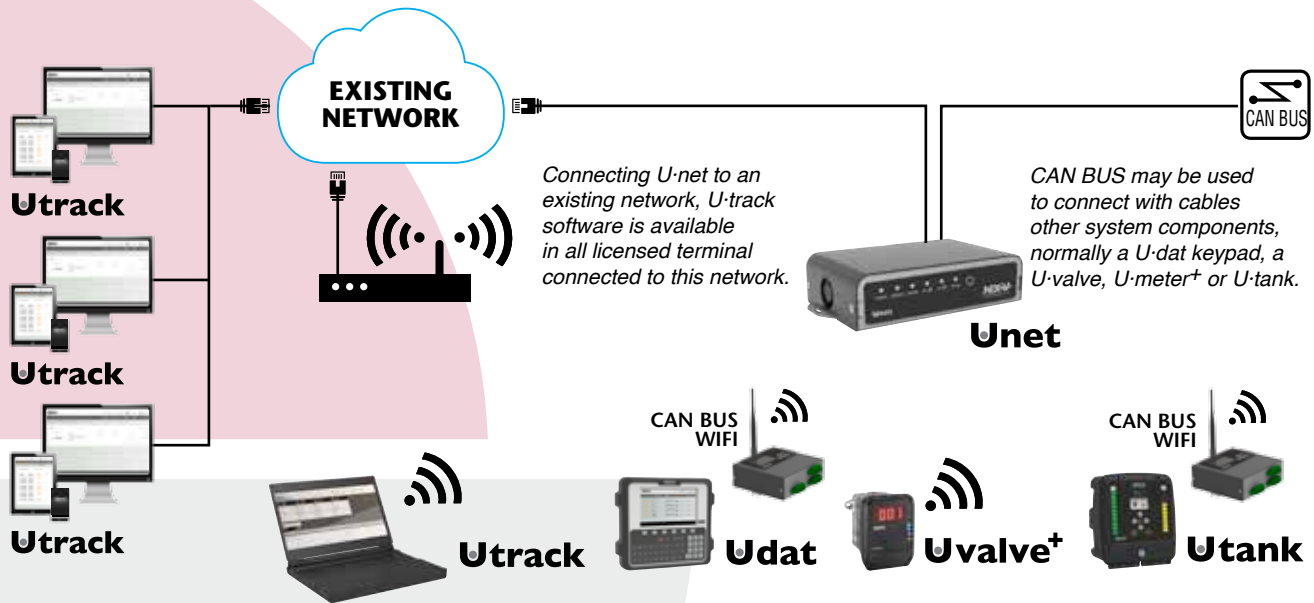

If the network uses Wi-Fi®, NEX-U® components with Wi-Fi® can connect to the network via Wi-Fi®. Additionally, other licensed terminals (laptops, tablets, Smartphones) can have access to U-track.

CREATING A NEW NETWORK

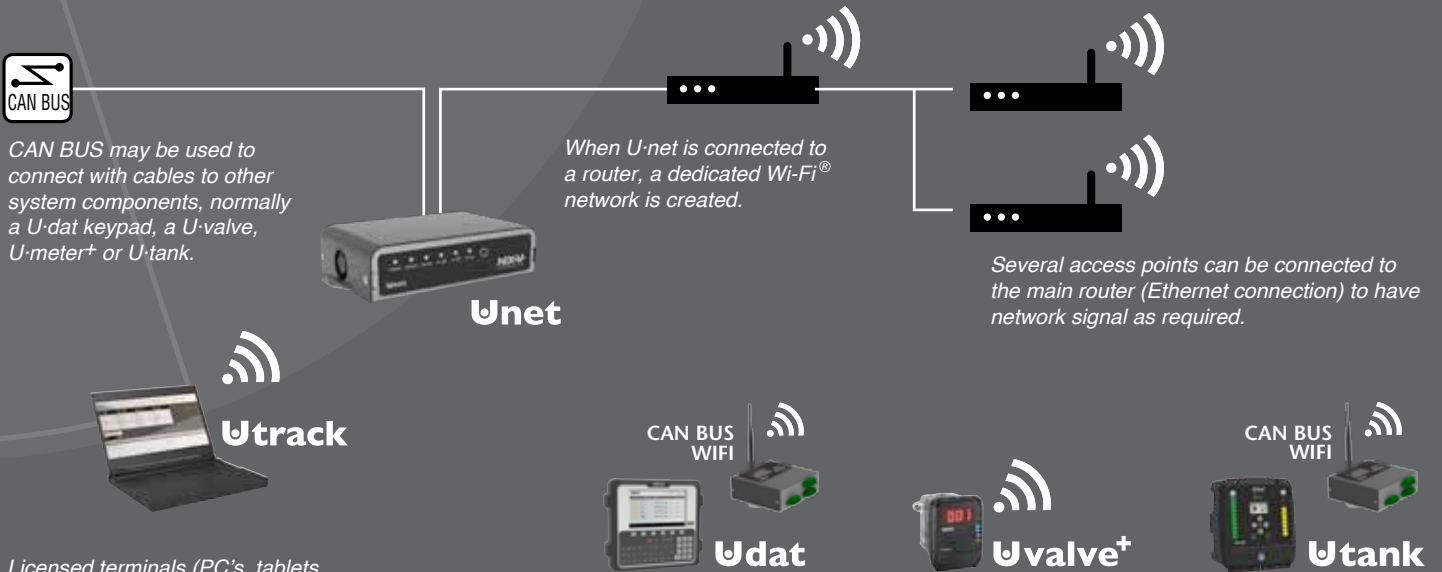

Licensed terminals (PC's, tablets, Smartphones) can connect to the NEX-U® network and have access to the NEX-U® system through U-track.

NEX-U® components can connect to the NEX-U® wireless network for data communication among them.

INSTALLATION EXAMPLES

NEX·U[®] provides maximum flexibility in the way the user interacts with the system, the most effective connection method and enhanced reporting capability.

ACCESS THROUGH U·dat

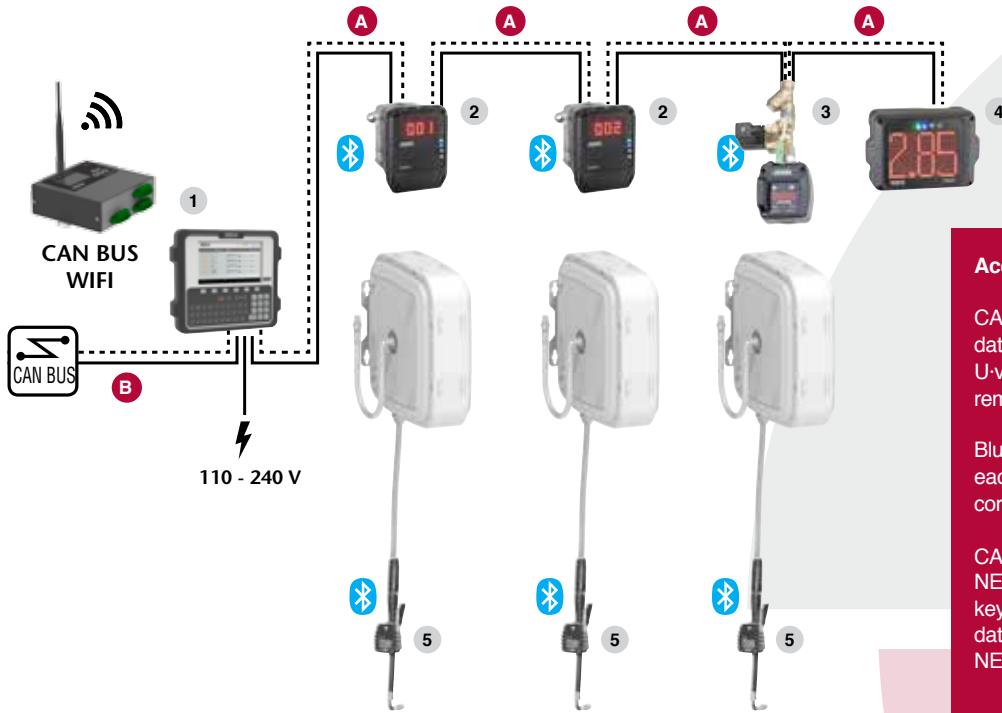

Access through U·dat

CAN BUS cable **A**, transmits power and data between the U·dat keypad **1**, the U·valves **2**, the U·meter⁺ **3** and the U·view remote display **4**.

Bluetooth[®] connection is used to communicate each U·valve **2** and U·meter⁺ **3** with its corresponding U·vision **5** hand-held display.

CAN BUS cable **B** communicates with other NEX·U[®] components. Alternatively, if the keypad **1**, is connected to the wireless network, data can be transmitted wirelessly to other NEX·U[®] components.

One U·net must be included in every NEX·U[®] installation (except NEX·U[®] Compact and NEX·U[®] Mobile).

ACCESS THROUGH U·vision⁺

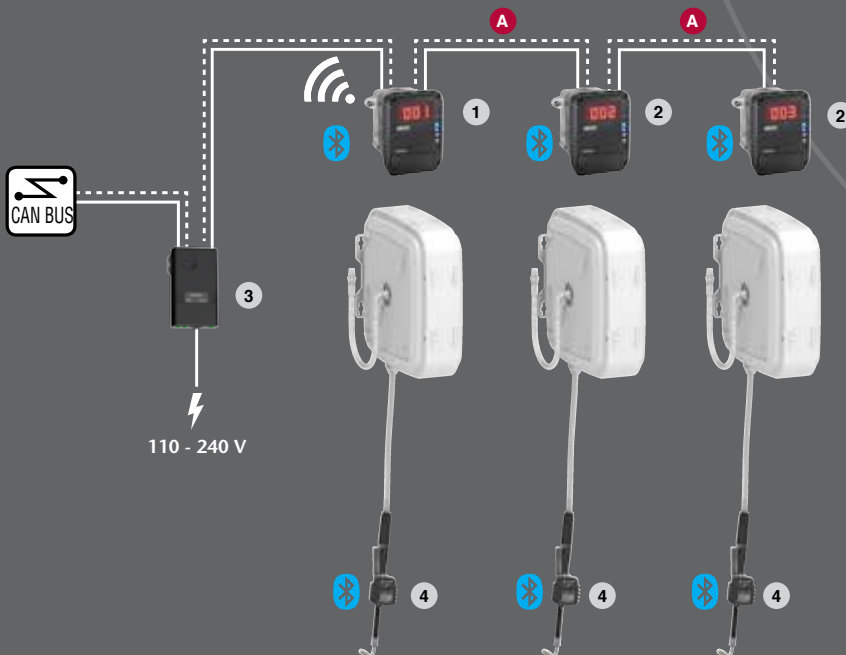

Access through U·vision⁺

Power and data are transmitted using CAN BUS cable **A** between the U·valve⁺ **1** and the other U·valves **2**. Power to energize the solenoid valves is supplied by the U·power **3**, connected to U·valve⁺ **1**.

Each U·valve⁺ **1** and U·valve **2** is connected to its corresponding U·vision⁺ **4**, hand-held display and systems access Keypad.

*Wireless data transmission is done by U·valve⁺ **1**.*

One U·net must be included in every NEX·U[®] installation (except NEX·U[®] Compact and NEX·U[®] Mobile).

PC - LAPTOP CONNECTION

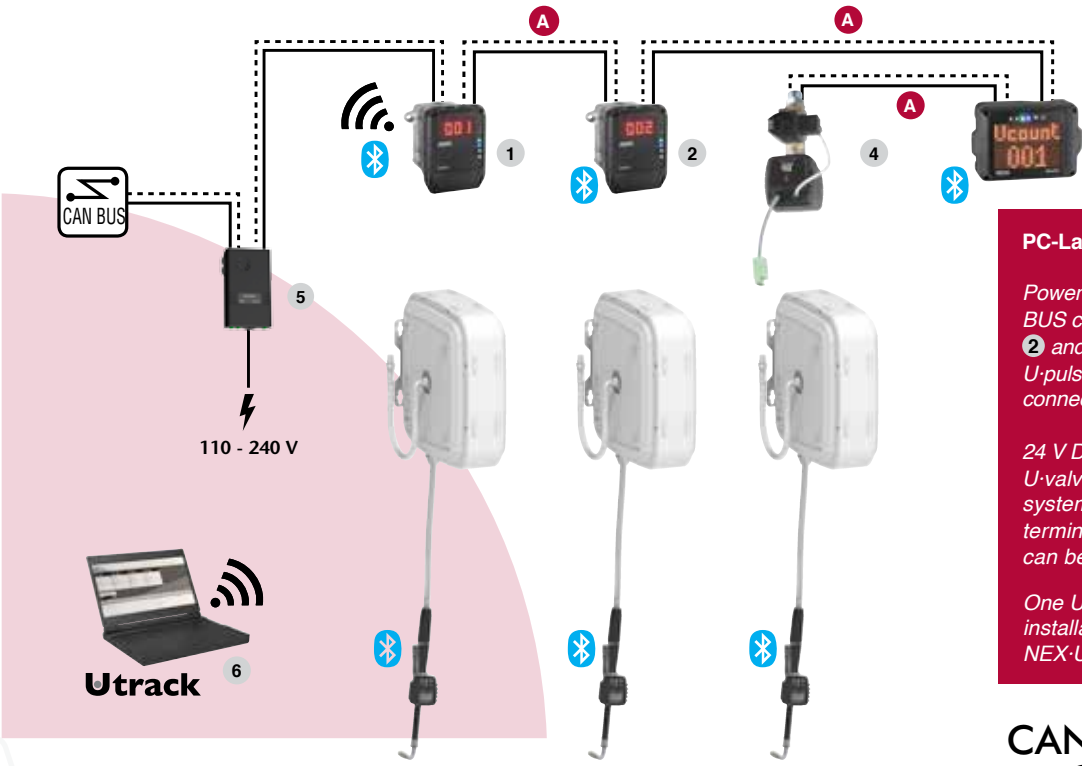

PC-Laptop connection

Power and data are transmitted using CAN BUS cable **A** between the U-valve+ **1**, U-valve **2** and U-count **3**. U-count **3** is connected to U-pulser solenoid valve **4** also using CAN BUS connection.

24 V DC power is supplied by U-power **5** to U-valve+ **1** connecting using Wi-Fi® with all system components, including any licensed terminal **6** that is connected to U-track and can be used as a virtual access keypad.

One U-net must be included in every NEX-U® installation (except NEX-U· Compact and NEX-U· Mobile).

CAN BUS FAST CONNECTION



U-dat, U-valve, U-meter, U-count, U-tank and U-net use in/out CAN BUS fast connectors that make cabling easier, quicker and prevent disconnections.

TANK MONITORING

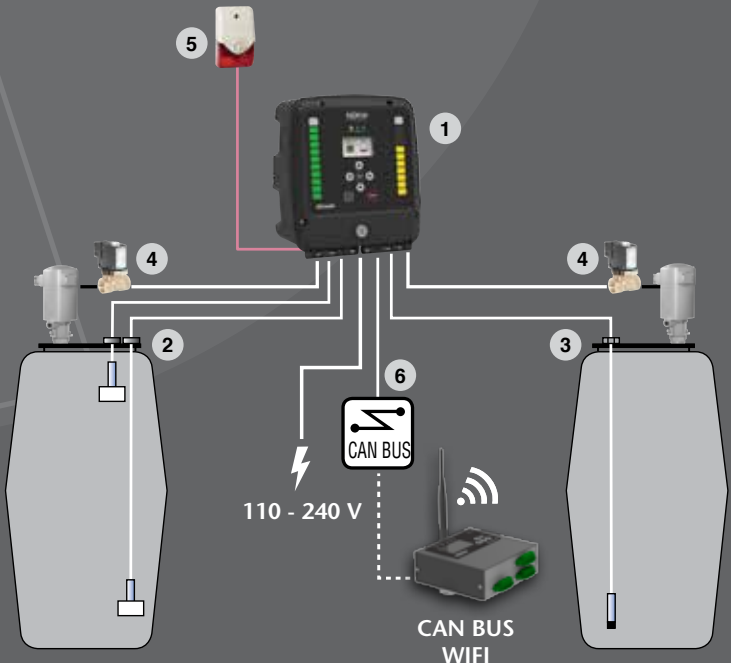

U-tank **1** can monitor up to two tanks. Each tank can be fitted with low and high level sensors **2** or with a pressure gauge **3** for real-time control of the inventory in the tank. U-tank **1** can also control pump operation opening or closing an air solenoid valve **4** that prevents pump from running dry or air entering the oil distribution lines if there is no oil in the tanks.

U-tank **1** can also control a remote flash light or siren **5** to warn when any tank is empty. U-tank **1** can communicate with other NEX-U® elements using Wi-Fi® or through CAN BUS **6** wired connection.

One U-net must be included in every NEX-U® installation (except NEX-U· Compact and NEX-U· Mobile).

Product specifications are subject to change without prior notice.



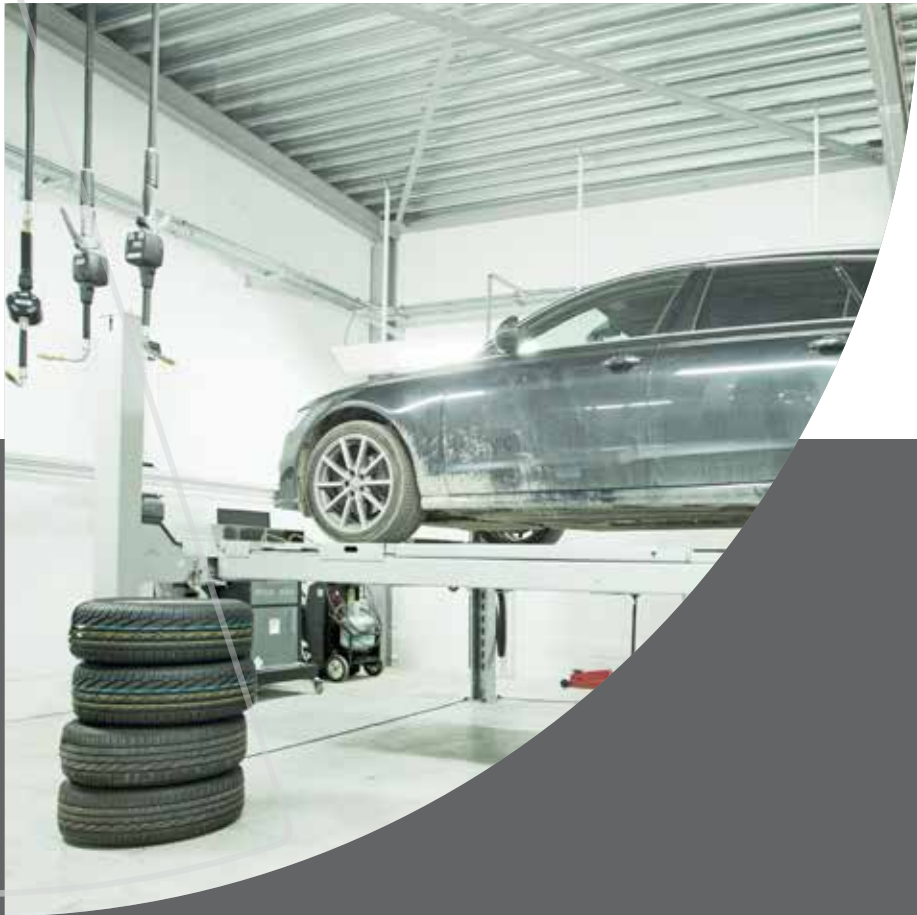



EUROLUBE EQUIPMENT by Alentec & Orion AB

Grustagsvägen 4

138 40 Älta

SWEDEN

Tel: +46 8 747 67 10

E-mail: eurolube@alentec.se

www.eurolube.com